

Num. articolo	Codice	CODICE_GESTIONALE	Descrizione	Materiale	Massa	Default/Q uantità
1	AS002151	AS002151	Telaio fustellatrice		42966.60	1
2	AS001848	AS001848	Gruppo fustellatura		50098.87	1
3	DR009079	DR009079	Carteratura cilindro	Anticorodal 6082	13183.61	1
4	DR001863	BET11316	Staffa di bloccaggio BET1 Part.1316	G AlSi 9 Mn Mg	29.55	4
5	AS001601	AS001601	Pulsantiera bimanuale con arresto e riarmo		1760.11	1
6	AS002156	AS002156	Gruppo regolatore pressione		1124.56	1
7	AS002159	AS002159	Gruppo valvole 1/4 pressa cilindro Hydro-Pneumatico GPA		2946.99	1
8	MAV 25 LEB OO	7010000400	Valvola manuale leva 90° 5/2 1/8"	Anticorodal 6082	605.09	1
9	W0970530052 (Default)	W0970530052	Silenziatore 1/8"	Ottone		2
10	21070001	21070001	Tappo G1/8"	Ottone	7.27	1
11	2L34002	2L34002	Maschio girevole (RL34) D4-G1/8"	Tecnopolimero		2

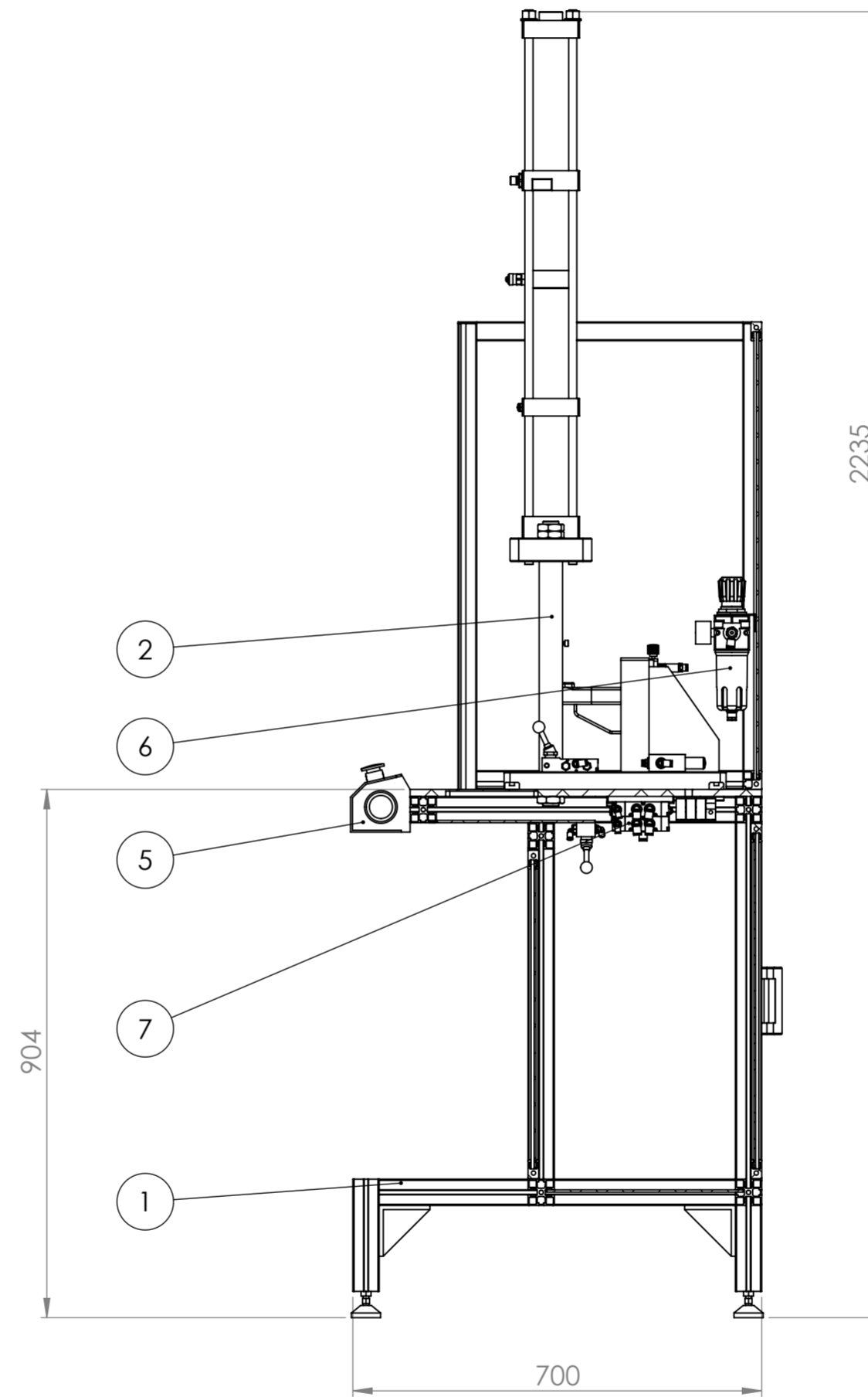

SEZIONE A-A
SCALA 1 : 10

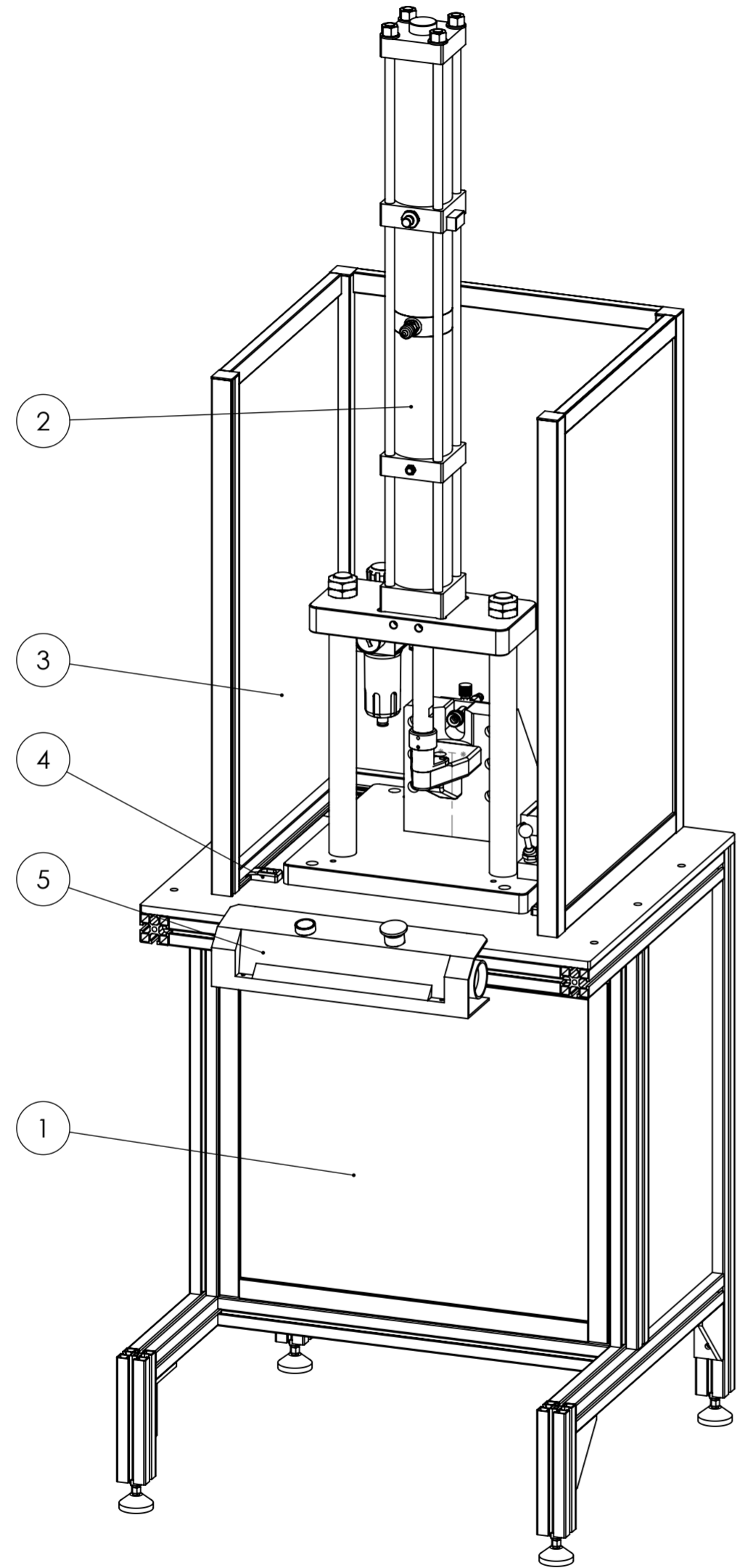
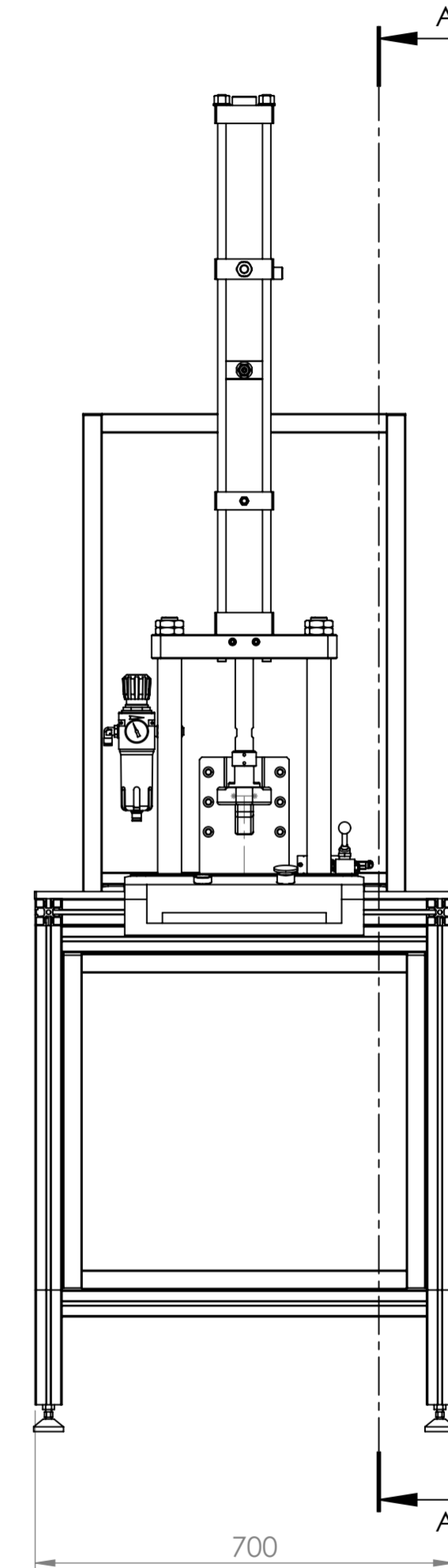

DOVE NON SPECIFICATO: Misure in Millimetri Smussi non Quotati: 0.5x45° Raccordi non Quotati: R1 Grado di precisione: MEDIO UNI5307		TRATTAMENTO TERMICO / FINITURA SUPERFICIALE	Stavare accuratamente gli spigoli vivi e non rilevare misure sul disegno	Cliente: OMAN di Negrelli Via del Mercato, 6/8 41037 Mirandola (MO) Tel / Fax: 0535-21180	Revisione: NUOVO
NAME DRAWN: Massimo Negrelli CHKD: APPVD:	SIGNATURE DATE 03-12-2019	DESCRIZIONE: Fustellatrice per maschera		DWG NO. AS002155-	A2
MATERIALE / STATO:		ID: AS002155		Massa [gr]: 112705.90	SHEET 1 OF 2



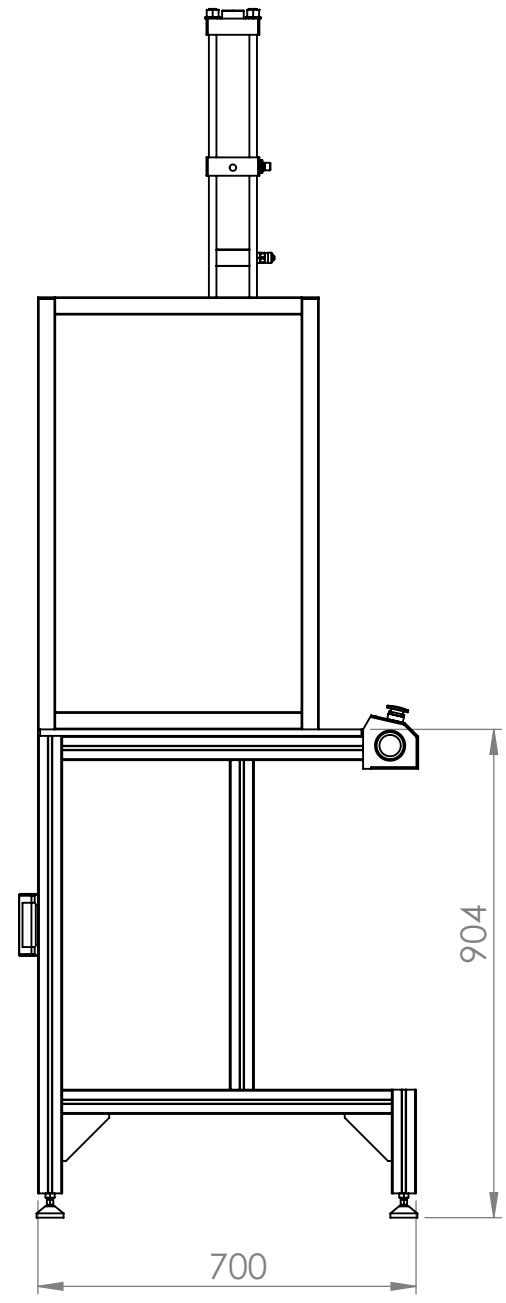
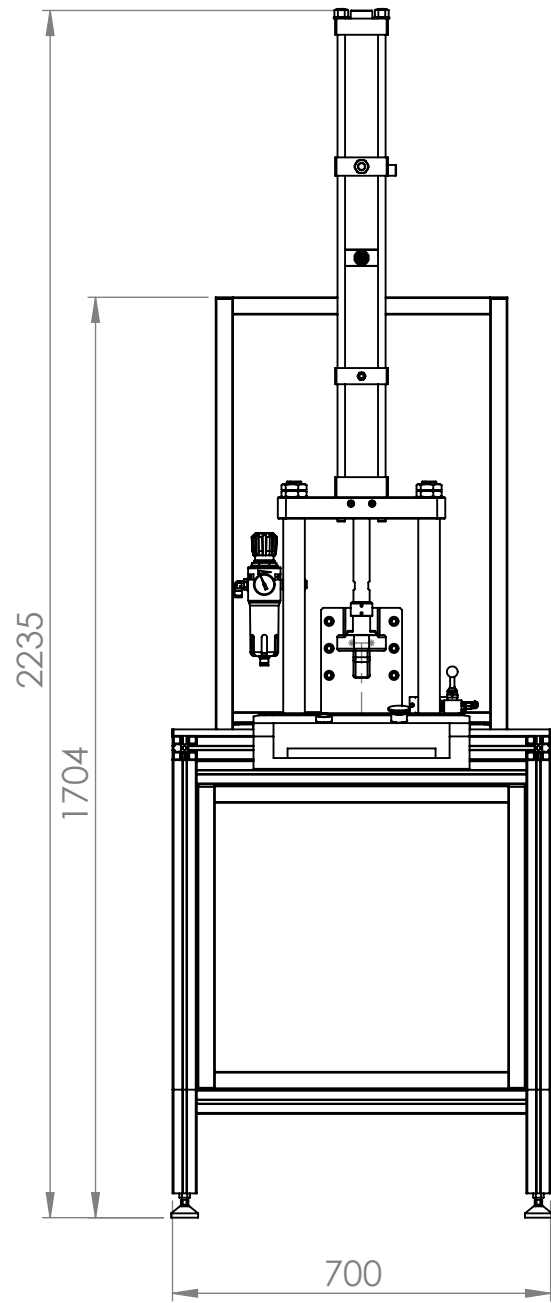

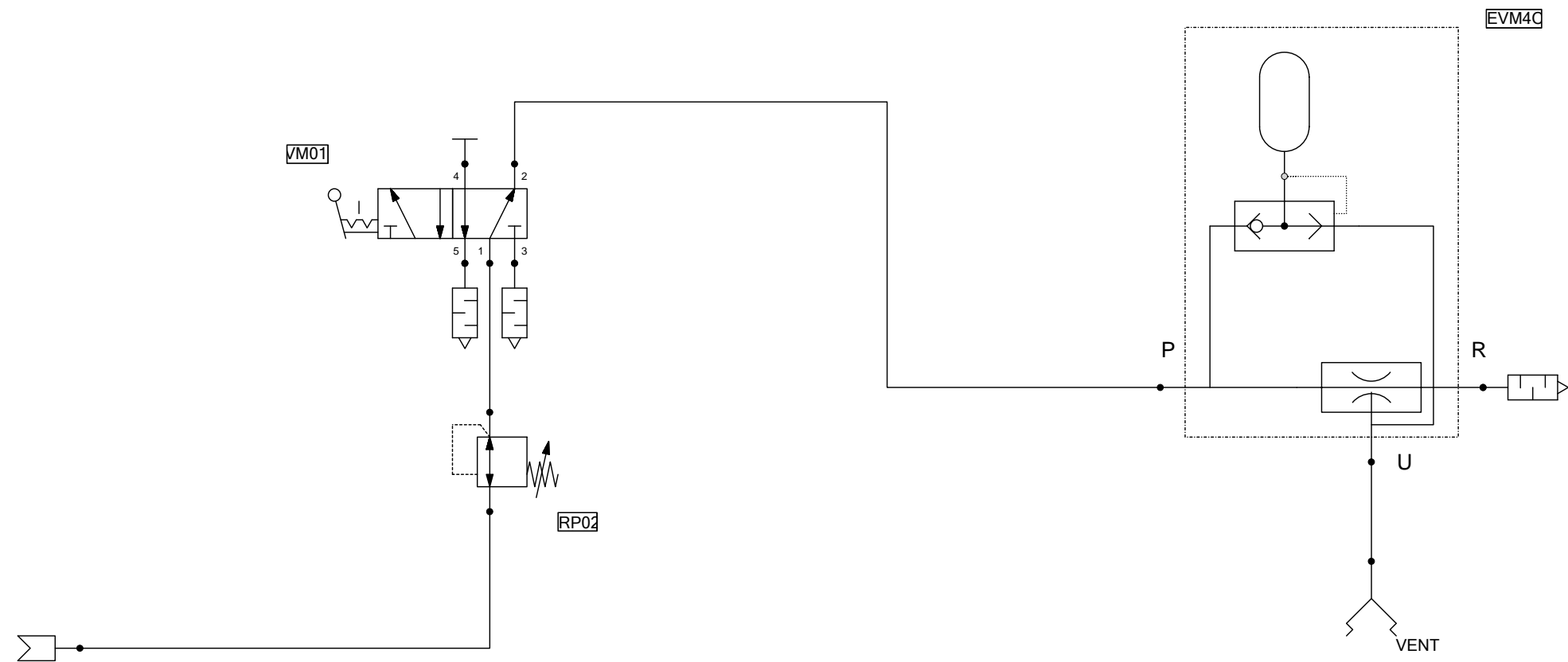

MODIFICHE	N°						Autore Negrelli M.	Data 19/12/2019
	Data							
	Firma							
		Progetto: AS002155 Tranciante DIMAR Cliente: DIMAR Descrizione: Pressa con cilindro Hydrop...					Gruppo ventosa	
								